

The SuperPhobic® Membrane Contactor that you have purchased can be damaged through improper handling and storage. The following guidelines are intended to provide a framework for successful storage of these contactors. If you have any questions, please contact your Membrana representative.

**Handling.** Proper handling of contactors is critical. Care must be taken not to hit or jar (shock) the contactor to minimize the possibility of internal damage. It is recommended that the contactors be stored in a dry, heat-sealed plastic bag or shrink wrap material [0.076 mm (0.003 in.) wall thickness] in their original box to prevent the introduction of contaminants into the contactor.

**Temperature.** Store contactors dry in their original boxes at temperatures not to exceed 49°C (120°F). Contactors stored at very low temperatures < 5°C (41°F) should be allowed to equilibrate to room temperature prior to introducing water.

**Humidity.** It is recommended that contactors be stored at low to moderate humidity levels (< 60% relative humidity).

**Exposure to Sunlight.** Contactors should not be stored where they are exposed to direct sunlight. Contactors should always be stored in sealed bags, or shrink wrap material, in the original box or other opaque box.

Manufactured with Sound Engineering Practice per Article 3, paragraph 3 of 97/23/EC.



This product is to be used only by persons familiar with its use. It must be maintained within the stated limitations. All sales are subject to Seller's terms and conditions. Purchaser assumes all responsibility for the suitability and fitness for use as well as for the protection of the environment and for health and safety involving this product. Seller reserves the right to modify this document without prior notice. Check with your representative to verify the latest update. To the best of our knowledge, the information contained herein is accurate. However, neither Seller nor any of its affiliates assumes any liability whatsoever for the accuracy or completeness of the information contained herein. Determination of the suitability of any material and infringement of any third party rights, including patent, trademark, or copyright rights, are the sole responsibility of the user. Users of any substance should satisfy themselves by independent investigation that the material can be used safely. We may have described certain hazards, but we cannot guarantee that these are the only hazards that exist. Nothing herein shall be construed as a recommendation or license to use any information that conflicts with any patent, trademark or copyright of Seller or others. Please read our Operating Manuals carefully before installing and using these modules.



THE INFORMATION CONTAINED HEREIN AND SELLER'S PRODUCTS ARE PROVIDED "AS IS" WITHOUT WARRANTY OF ANY KIND, EITHER EXPRESSED OR IMPLIED, INCLUDING, BUT NOT LIMITED TO, THE IMPLIED WARRANTIES OF MERCHANTABILITY, FITNESS FOR ANY PARTICULAR PURPOSE OR USE, OR NON-INFRINGEMENT OF INTELLECTUAL PROPERTY. IN NO EVENT SHALL SELLER BE LIABLE FOR ANY SPECIAL, INCIDENTAL, INDIRECT, OR CONSEQUENTIAL DAMAGES OF ANY KIND, OR ANY DAMAGES WHATSOEVER RESULTING FROM THE USE OF INFORMATION CONTAINED HEREIN AND SELLER'S PRODUCTS.

Liqui-Cel®, SuperPhobic®, MiniModule®, and MicroModule® are registered trademarks of Membrana-Charlotte, A Division of Celgard, LLC.

Copyright © 2011 Membrana – Charlotte

All rights reserved.

SU4\_Rev5 1x3 and 2x6 Start-up\_07/08

**SERVICE QUESTIONS:** Contact your OEM or your Membrana representative.

**Membrana - Charlotte**  
A Division of Celgard, LLC  
13800 South Lakes Drive  
Charlotte, North Carolina 28273  
USA  
Phone: (704) 587 8888  
Fax: (704) 587 8610

**Membrana GmbH**  
Oehder Strasse 28  
D-42289 Wuppertal  
Germany  
Phone: +49 202 6099 -658  
Phone: +49 6126 2260 -41  
Fax: +49 202 6099 -750

**Japan Office**  
Shinjuku Mitsui Building, 27F  
1-1, Nishishinjuku 2-chome  
Shinjuku-ku, Tokyo 163-0427  
Japan  
Phone: +81-3-5324 3361  
Fax: +81-3-5324 3369

[www.liqui-cel.com](http://www.liqui-cel.com)



## START - UP PROCEDURES for 1 x 3 and 2 x 6 Radial Flow Contactors



## START-UP PROCEDURES

### Steps:

1. Mount contactor vertically or horizontally.
2. Refer to the start-up procedures below. Both contactors operate in vacuum only mode so the start-up is the same for both products. Just be certain to correctly connect the liquid and vacuum ports as shown in the illustrations below.

## SuperPhobic 1 x 3 and 2 x 6 Membrane Contactors

### NOTES:

- The liquid pressure should always be higher than the gas phase pressure inside the contactor.
- Liquid must flow on the shell side (outside) of the fiber.
- The Liquid and Vacuum port identifications are engraved on the 2x6 contactor.
- Incoming fluid should be prefiltered at 10  $\mu\text{m}$ .

## THE OPERATING MODE IS VACUUM ONLY FOR BOTH DEVICES

### Vertically Mounted Module

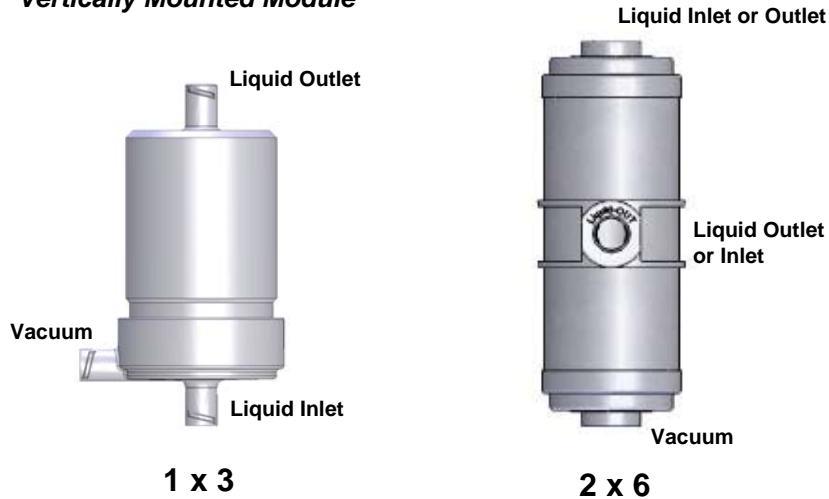

### Horizontally Mounted Module

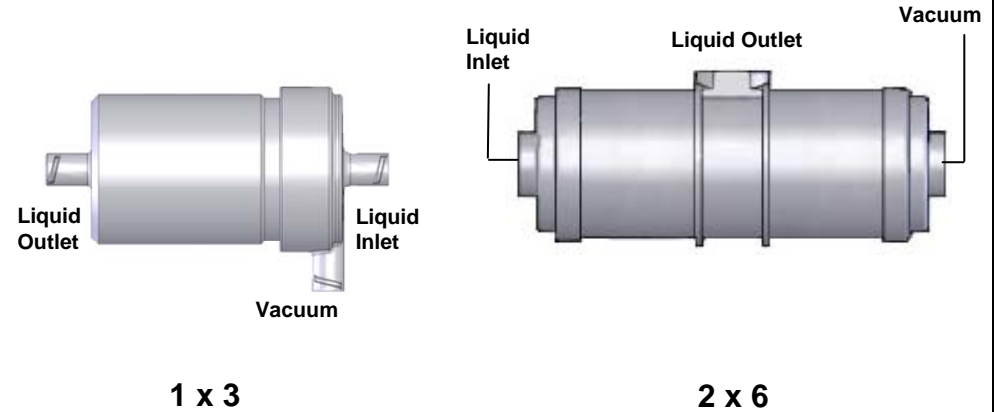

## START-UP PROCEDURES

### A. General start-up instructions for the liquid phase

**Note:** The gas/vacuum port should not be closed off during operation.

1. Connect the liquid inlet/outlet ports and the vacuum port as shown in the illustrations above. For 2x6, either liquid port can be used for the inlet.
2. Slowly introduce liquid into the contactor, making sure that the liquid inlet pressure and liquid flow rate through the contactor never exceed the respective maximum operating limits: The liquid must flow on the shellside of a SuperPhobic Contactor. (Labeled with Liquid Inlet/Outlet above).

Product	Maximum Pressure*	Maximum Flow Rate
1 x 3	25° C, 3.1 bar (77° F, 3.2 kg/cm <sup>2</sup> , 45 psig)	60 ml/min
	40° C, 1.0 bar (104° F, 1.1 kg/cm <sup>2</sup> , 15 psig)	
2 x 6	4.1 bar, 25° C (4.2 kg/cm <sup>2</sup> , 60 psig, 77°F)	1000 ml/min

\* using 50 torr (mm Hg) vacuum on vacuum port.

3. Adjust the liquid flow rate and inlet pressure to the desired levels by adjusting the appropriate valves on the system.

### Vacuum Mode

1. Start vacuum pump following the vacuum pump manufacturer's instructions.
2. Apply vacuum to the contactor by opening appropriate valve.
3. Adjust absolute gas pressure on the vacuum side to the desired level at the vacuum port on the contactor (absolute pressure depends on gauge vacuum as well as barometric pressure).

A general rule of thumb regarding the minimum vacuum pressure is to maintain a vacuum level such that the absolute pressure on the vacuum side of the membrane is higher than the vapor pressure of the most volatile component in the liquid (water or solvent, etc.) at the operating temperature.

For example: if an ink is water based and the operating temperature is 25 C, the water vapor pressure would be around 20-22 torr (mm Hg) absolute. If this is the case, then the absolute pressure on the vacuum side should be around 25-30 torr, no lower. Normally, we would suggest pulling a vacuum no deeper than 30 torr.