

Power Plant in Thailand Uses Liqui-Cel® Membrane Contactors to Remove CO₂ From Water

A major power plant in Thailand is using Liqui-Cel® Membrane Contactors to remove carbon dioxide from a DI water system. The system is an expansion project and will be used to feed a high pressure boiler. Liqui-Cel Contactors are being used to lower the CO₂ inlet into an Ionpure EDI system. Carbon dioxide adds an ionic load to the EDI system, which can reduce the performance of the system. Manufacturers of the EDI equipment suggest lowering the inlet CO₂ to reduce the load on the equipment and improve the water quality.

The system was designed, built and installed by Liquid Purification Engineering International Co., Ltd. in Bangkok Thailand. LPE designed the DI water system as an all membrane based system that does not require the use of ion exchange resin or chemicals. The system uses a double pass RO membrane, a Liqui-Cel Membrane Contactor and Ionpure EDI technology. The system produces water with a resistivity >16.0 MΩ-cm. (See water quality and flow diagram.)

The Liqui-Cel Membrane Contactor system consists of one 14-inch Membrane Contactor that operates in combination mode using vacuum and air sweep.

Liqui-Cel Membrane Contactors utilize a hydrophobic polypropylene membrane to remove dissolved gasses from water. Water flows on one side of the membrane and a vacuum or strip gas is passed on the other side of the membrane. In this system air is drawn into the membrane under vacuum. The high flow rate of air sweep under vacuum creates a driving force to move the dissolved carbon dioxide from the water into the gas phase.

Historically, forced draft deaerators have been used to remove CO₂ from water. This type of deaerator uses ambient air that is fed into the tower with a blower, putting the air in direct contact with the water. This direct air-to-water contact opens the system up to possible water

Water Quality Influent Analysis Water Source	Clarified Surface Water
Turbidity, NTU	0.8-5
pH	6.5-8
Conductivity, Micro siemen-cm	400
TDS, mg/l	280
M- Alkalinity, mg/l as CaCO ₃	100
Total Hardness, mg/l as CaCO ₃	120
Calcium Hardness, mg/l as CaCO ₃	75
Chloride, mg/l as Cl ⁻	45
Iron, mg/l as Fe	0.01
Sulfate, mg/l as SO ₄	26
Phosphate, mg/l as PO ₄	0.03
Silica, mg/l as SiO ₂	15
Effluent Quality, RO feed	
Turbidity, NTU	<0.5
SDI	<3
Effluent Quality, DI. water	
Resistivity, MΩ-cm	>16.0
Silica, mg/l as SiO ₂	<0.02

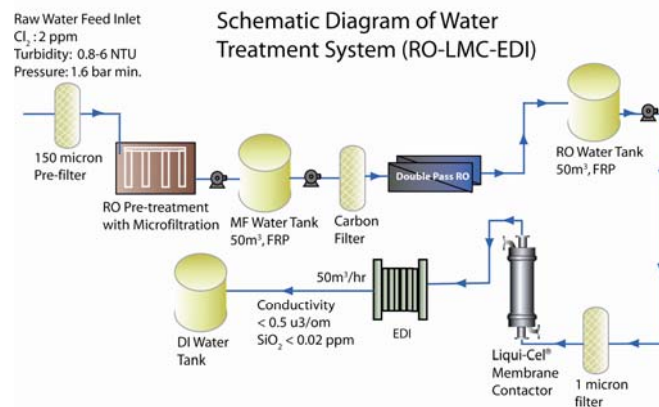

contamination from any contaminants that are present in the air. For this reason, using a forced draft deaerator downstream of an RO membrane system is not recommended.

Membrane Contactors, however, are well suited to remove dissolved carbon dioxide and other dissolved gasses along side of an RO membrane system because the membrane has tight 0.03 μm pores that prevent air stream contamination from coming into contact with the RO water.

Membrane Contactors are mechanical devices that remove the dissolved carbon dioxide gas that will ionize in water and be present in both gaseous

and ionic forms. The amount of CO₂ gas present in the water depends on the pH of the water. The lower the pH, the greater the amount of CO₂ present in the water. Due to the natural decrease of pH across the RO membrane system, the pH inlet to the membrane contactor is below 6. This favors the formation of CO₂ gas and allows the membrane contactor to efficiently remove CO₂ gas from the water.

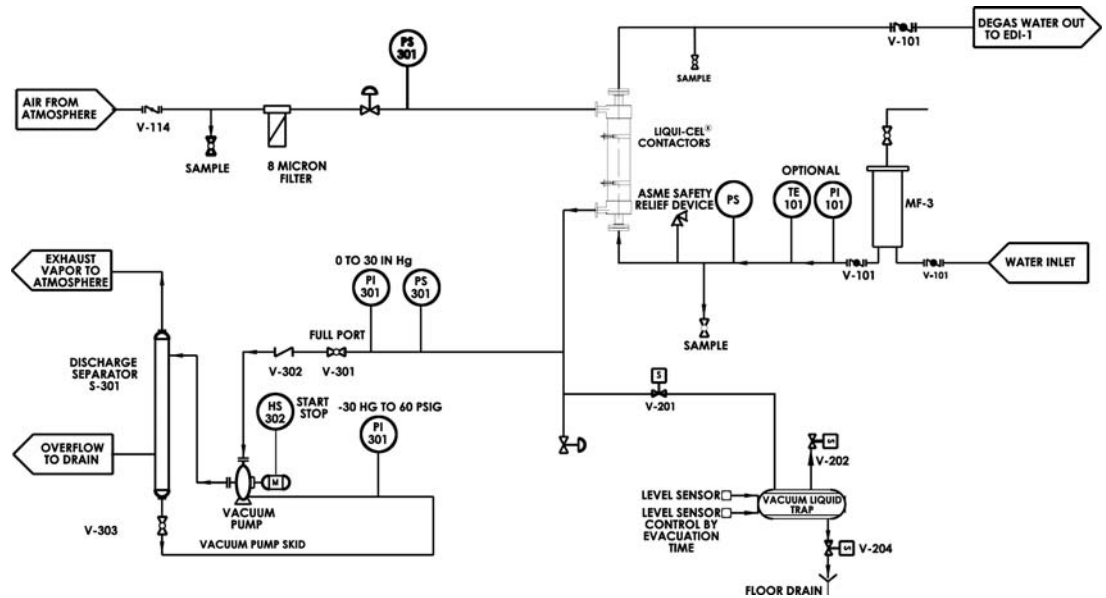

The power plant is very pleased with the membrane based DI water system. It requires little maintenance and exceeds the performance specifications for the system. In addition, by incorporating Liqui-Cel Membrane Contactors into the system to remove carbon dioxide the amount of chemicals used in the plant are reduced. By mechanically removing the CO₂ the end user did not need to adjust the pH down to facilitate removal by the RO membrane system or use ion exchange beds upstream of the EDI to lower the CO₂ load on the EDI.

Liqui-Cel Membrane Contactors are used in thousands of systems throughout the world to remove dissolved gasses from water. This design is one example of how membrane contactors can be used in a water system. Please visit our web site at www.liqui-cel.com for more information on Liqui-Cel Membrane Contactor installations and applications.



This product is to be used only by persons familiar with its use. It must be maintained within the stated limitations. All sales are subject to Seller's terms and conditions. Purchaser assumes all responsibility for the suitability and fitness for use as well as for the protection of the environment and for health and safety involving this product. Seller reserves the right to modify this document without prior notice. Check with your representative to verify the latest update. To the best of our knowledge the information contained herein is accurate. However, neither Seller nor any of its affiliates assumes any liability whatsoever for the accuracy or completeness of the information contained herein. Final determination of the suitability of any material and whether there is any infringement of patents, trademarks, or copyrights is the sole responsibility of the user. Users of any substance should satisfy themselves by independent investigation that the material can be used safely. We may have described certain hazards, but we cannot guarantee that these are the only hazards that exist.

Liqui-Cel, Celgard, SuperPhobic and MiniModule are registered trademarks and NB is a trademark of Membrana-Charlotte, A division of Celgard, LLC and nothing herein shall be construed as a recommendation or license to use any information that conflicts with any patent, trademark or copyright of Seller or others.

©2009 Membrana – Charlotte A Division of Celgard, LLC

(TB56 Rev1 03-09)

Membrana – Charlotte
A Division of Celgard, LLC
13800 South Lakes Drive
Charlotte, North Carolina 28273
USA
Phone: (704) 587 8888
Fax: (704) 587 8585

Membrana GmbH
Oehder Strasse 28
42289 Wuppertal
Germany
Phone: +49 202 6099 - 658
Phone: +49 6126 2260 - 41
Fax: +49 202 6099 -750

Japan Office
Shinjuku Mitsui Building, 27F
1-1, Nishishinjuku 2-chome
Shinjuku-ku, Tokyo 163-0427
Japan
Phone: 81 3 5324 3361
Fax: 81 3 5324 3369

MEMBRANA
Underlining Performance

www.liqui-cel.com

A **POLYPOR** Company